

US



# Mig 5000i

## Aristo™

460 V version

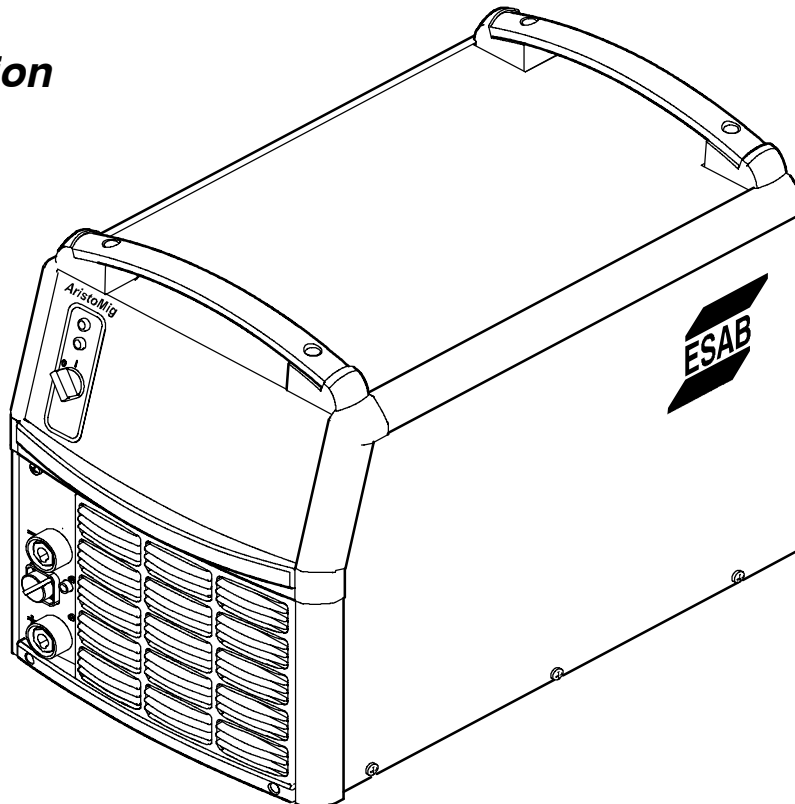

### CAUTION

These INSTRUCTIONS are for experienced operators. If you are not fully familiar with the principles of operation and safe practices for arc welding equipment, we urge you to read our booklet, "Precautions and Safe Practices for Arc, Cutting and Gouging," Form 52-529. Do NOT permit untrained persons to install, operate, or maintain this equipment. Do NOT attempt to install or operate this equipment until you have read and fully understand these instructions. If you do not fully understand these instructions, contact your supplier for further information. Be sure to read the Safety Precautions before installing or operating this equipment.

Be sure this information reaches the operator.  
You can get extra copies through your supplier.

Instruction manual

<b>1 SAFETY PRECAUTIONS</b> .....	<b>3</b>
<b>2 PRECAUCION DE SEGURIDAD</b> .....	<b>5</b>
<b>3 MESURES DE SECURITE</b> .....	<b>8</b>
<b>4 USER RESPONSIBILITY</b> .....	<b>11</b>
<b>5 SAFETY</b> .....	<b>11</b>
<b>6 INTRODUCTION</b> .....	<b>12</b>
6.1 Equipment .....	12
<b>7 TECHNICAL DATA</b> .....	<b>12</b>
<b>8 INSTALLATION</b> .....	<b>13</b>
8.1 Lifting instructions .....	13
8.2 Placing .....	13
8.3 Primary input .....	14
8.4 Terminating resistor .....	14
<b>9 OPERATION</b> .....	<b>15</b>
9.1 Connections and control devices .....	15
9.2 Turning on the power source .....	15
9.3 Fan control .....	16
9.4 Overheating protection .....	16
9.5 Remote control unit .....	16
<b>10 MAINTENANCE</b> .....	<b>16</b>
10.1 Cleaning the air filter .....	17
<b>11 TROUBLESHOOTING</b> .....	<b>17</b>
<b>12 REPLACEMENT AND REPAIR PARTS</b> .....	<b>17</b>
12.1 Ordering .....	18
<b>SCHEMATIC DIAGRAM</b> .....	<b>20</b>
<b>ORDERING NUMBER</b> .....	<b>23</b>
<b>REPLACEMENT PARTS</b> .....	<b>24</b>
<b>ACCESSORIES</b> .....	<b>25</b>

# 1 SAFETY PRECAUTIONS



**WARNING:** These Safety Precautions are for your protection. They summarize precautionary information from the references listed in Additional Safety Information section. Before performing any installation or operating procedures, be sure to read and follow the safety precautions listed below as well as all other manuals, material safety data sheets, labels, etc. Failure to observe Safety Precautions can result in injury or death.



## PROTECT YOURSELF AND OTHERS

**Some welding, cutting and gouging processes are noisy and require ear protection. The arc, like the sun, emits ultraviolet (UV) and other radiation and can injure skin and eyes. Hot metal can cause burns. Training in the proper use of the processes and equipment is essential to prevent accidents. Therefore:**

1. Always wear safety glasses with side shields in any work area, even if welding helmets face shields and goggles are also required.
2. Use a face shield fitted with the correct filter and cover plates to protect your eyes, face, neck and ears from sparks and rays of the arc when operating or observing operations. Warn bystanders not to watch the arc and not to expose themselves to the rays of the electric-arc or hot metal.
3. Wear flameproof gauntlet type gloves, heavy long-sleeve shirt, cuffless trousers, high-topped shoes and a welding helmet or cap for protection, to protect against arc rays and hot sparks or hot metal. A flameproof apron may also be desirable as protection against radiated heat and sparks.
4. Hot sparks or metal can lodge in rolled up sleeves, trouser cuffs, or pockets. Sleeves and collars should be kept buttoned and open pockets eliminated from the front of clothing.
5. Protect other personnel from arc rays and hot sparks with a suitable nonflammable partition or curtains.
6. Use goggles over safety glasses when chipping slag or grinding. Chipped slag may be hot and can fly far. Bystanders should also wear goggles over safety glasses.



## FIRES AND EXPLOSIONS

**Heat from flames and arcs can start fires. Hot slag or sparks can also cause fires and explosions. Therefore:**

1. Remove all combustible materials well away from the work area or cover the materials with a protective nonflammable covering. Combustible materials include wood, cloth, sawdust, liquid and gas fuels, solvents, paints and coatings paper, etc.
2. Hot sparks or hot metal can fall through cracks or crevices in floors or wall openings and cause a hidden smoldering fire or fires on the floor below. Make certain that such openings are protected from hot sparks and metal.
3. Do not weld, cut or perform other hot work until the workpiece has been completely cleaned so that there are no substances on the workpiece which might produce flammable or toxic vapors. Do not do hot work on closed containers. They may explode.
4. Have fire extinguishing equipment handy for instant use, such as a garden hose, water pail, sand bucket, or portable fire extinguisher. Be sure you are trained in its use.
5. Do not use equipment beyond its ratings. For example, overloaded welding cable can overheat and create a fire hazard.
6. After completing operations, inspect the work area to make certain there are no hot sparks or hot metal which could cause a later fire. Use fire watchers when necessary.
7. For additional information refer to NFPA Standard 51B, "Fire Prevention in Use of Cutting and Welding Processes", available from the National Fire Protection Association, Batterymarch Park, Quincy, MA 02269.



## ELECTRICAL SHOCK

**Contact with live electrical parts and ground can cause severe injury or death. DO NOT use AC welding current in damp areas, if movement is confined, or if there is danger of falling. Therefore:**

1. Be sure the power source frame (chassis) is connected to the ground system of the input power.
2. Connect the workpiece to a good electrical ground.
3. Connect the work cable to the workpiece. A poor or missing connection can expose you or others to a fatal shock.
4. Use well-maintained equipment. Replace worn or damaged cables.
5. Keep everything dry, including clothing, work area, cables, torch/electrode holder and power source.
6. Make sure that all parts of your body are insulated from work and from ground.
7. Do not stand directly on metal or the earth while working in tight quarters or a damp area; stand on dry boards or an insulating platform and wear rubber-soled shoes.
8. Put on dry, hole-free gloves before turning on the power.
9. Turn off the power before removing your gloves.
10. Refer to ANSI/ASC Standard Z49.1 (listed on next page) for specific grounding recommendations. Do not mistake the work lead for a ground cable.



### **ELECTRIC AND MAGNETIC FIELDS**

**May be dangerous. Electric current flowing through any conductor causes localized Electric and Magnetic Fields (EMF). Welding and cutting current creates EMF around welding cables and welding machines.**

**Therefore:**

1. Welders having pacemakers should consult their physician before welding. EMF may interfere with some pacemakers.
2. Exposure to EMF may have other health effects which are unknown.
3. Welders should use the following procedures to minimize exposure to EMF:
  - a. Route the electrode and work cables together. Secure them with tape when possible.
  - b. Never coil the torch or work cable around your body.
  - c. Do not place your body between the torch and work cables. Route cables on the same side of your body.
  - d. Connect the work cable to the workpiece as close as possible to the area being welded.
  - e. Keep welding power source and cables as far away from your body as possible.



### **FUMES AND GASES**

**Fumes and gases, can cause discomfort or harm, particularly in confined spaces. Do not breathe fumes and gases. Shielding gases can cause asphyxiation.**

**Therefore:**

1. Always provide adequate ventilation in the work area by natural or mechanical means. Do not weld, cut or gouge on materials such as galvanized steel, stainless steel, copper, zinc, lead beryllium or cadmium unless positive mechanical ventilation is provided. Do not breathe fumes from these materials.
2. Do not operate near degreasing and spraying operations. The heat or arc can react with chlorinated hydrocarbon vapors to form phosgene, a highly toxic gas and other irritant gases.
3. If you develop momentary eye, nose or throat irritation while operating, this is an indication that ventilation is not adequate. Stop work and take necessary steps to improve ventilation in the work area. Do not continue to operate if physical discomfort persists.
4. Refer to ANSI/ASC Standard Z49.1 (see listing below) for specific ventilation recommendations.
5. **WARNING:** This product when used for welding or cutting, produces fumes or gases which contain chemicals known to the State of California to cause birth defects and in some cases cancer (California Health & Safety Code §25249.5 et seq.)



### **CYLINDER HANDLING**

**Cylinders, if mishandled, can rupture and violently release gas. Sudden rupture of cylinder valve or relief device can injure or kill.**

**Therefore:**

1. Use the proper gas for the process and use the proper pressure reducing regulator designed to operate from the compressed gas cylinder. Do not use adaptors. Maintain hoses and fittings in good condition. Follow manufacturer's operating instructions for mounting regulator to a compressed gas cylinder.
2. Always secure cylinders in an upright position by chain or strap to suitable hand trucks, undercarriages, benches, wall, post or racks. Never secure cylinders to work tables or fixtures where they may become part of an electrical circuit.
3. When not in use, keep cylinder valves closed. Have valve protection cap in place if regulator is not connected. Secure and move cylinders by using suitable hand trucks.
4. Locate cylinders away from heat, sparks and flames. Never strike an arc on a cylinder.
5. For additional information, refer to CGA Standard P-1, "Precautions for Safe Handling of Compressed Gases in Cylinders", which is available from Compressed Gas Association, 1235 Jefferson Davis Highway, Arlington, VA 22202.



### **EQUIPMENT MAINTENANCE**

**Faulty or improperly maintained equipment can cause injury or death. Therefore:**

1. Always have qualified personnel perform the installation, troubleshooting and maintenance work. Do not perform any electrical work unless you are qualified to perform such work.
2. Before performing any maintenance work inside a power source, disconnect the power source from the incoming electrical power.
3. Maintain cables, grounding wire, connections, power cord and power supply in safe working order. Do not operate any equipment in faulty condition.
4. Do not abuse any equipment or accessories. Keep equipment away from heat sources such as furnaces, wet conditions such as water puddles, oil or grease, corrosive atmospheres and inclement weather.
5. Keep all safety devices and cabinet covers in position and in good repair.
6. Use equipment only for its intended purpose. Do not modify it in any manner.



#### ADDITIONAL SAFETY INFORMATION

For more information on safe practices for electric arc welding and cutting equipment, ask your supplier for a copy of "Precautions and Safe Practices for Arc Welding, Cutting and Gouging", Form 52-529.

The following publications, which are available from the American Welding Society, 550 N.W. LeJeune Road, Miami, FL 33126, are recommended to you:

1. ANSI/ASC Z49.1 - "Safety in Welding and Cutting"
2. AWS C5.1 . "Recommended Practices for Plasma Arc Welding"
3. AWS C5.2 - "Recommended Practices for Plasma Arc Cutting"
4. AWS C5.3 - "Recommended Practices for Air Carbon, Arc Gouging and Cutting"
5. AWS C5.5 - "Recommended Practices for Gas Tungsten Arc Welding"
6. AWS C5.6 - "Recommended Practices for Gas Metal Arc welding"
7. AWS SP - "Safe practices" - Reprint, Welding Handbook
8. ANSI/AWS F4.1 - "Recommended Safe Practices for Welding and Cutting of Containers That Have Held Hazardous Substances"



#### MEANING OF SYMBOLS

As used throughout this manual: Means Attention! Be Alert!



**DANGER**

Means immediate hazards which, if not avoided, will result in immediate, serious personal injury or loss of life.



**WARNING**

Means potential hazards which could result in personal injury or loss of life.



**CAUTION**

Means hazards which could result in minor personal injury.

## 2 PRECAUCION DE SEGURIDAD



**ADVERTENCIA:** Estas Precauciones de Seguridad son para su protección. Ellas hacen resumen de información proveniente de las referencias listadas en la sección "Información Adicional Sobre La Seguridad". Antes de hacer cualquier instalación o procedimiento de operación, asegúrese de leer y seguir las precauciones de seguridad listadas a continuación así como también todo manual, hoja de datos de seguridad del material, calcomanías, etc. El no observar las Precauciones de Seguridad puede resultar en daño a la persona o muerte.



#### PROTEJASE USTED Y A LOS DEMAS

Algunos procesos de soldadura, corte y ranurado son ruidosos y requieren protección para los oídos. El arco, como el sol, emite rayos ultravioleta (UV) y otras radiaciones que pueden dañar la piel y los ojos. El metal caliente causa quemaduras. EL entrenamiento en el uso propio de los equipos y sus procesos es esencial para prevenir accidentes.

Por lo tanto:

1. Utilice gafas de seguridad con protección a los lados siempre que esté en el área de trabajo, aún cuando esté usando careta de soldar, protector para su cara u otro tipo de protección.
2. Use una careta que tenga el filtro correcto y lente para proteger sus ojos, cara, cuello, y oídos de las chispas y rayos del arco cuando se esté operando y observando las operaciones. Alerta a todas las personas cercanas de no mirar el arco y no exponerse a los rayos del arco eléctrico o el metal fundido.
3. Use guantes de cuero a prueba de fuego, camisa pesada de mangas largas, pantalón de ruedo liso, zapato alto al tobillo, y careta de soldar con capucha para el pelo, para proteger el cuerpo de los rayos y chispas calientes provenientes del metal fundido. En ocasiones un delantal a prueba de fuego es necesario para protegerse del calor radiado y las chispas.
4. Chispas y partículas de metal caliente puede alojarse en las mangas enrolladas de la camisa, el ruedo del pantalón o los bolsillos. Mangas y cuellos deberán mantenerse abotonados, bolsillos al frente de la camisa deberán ser cerrados o eliminados.
5. Proteja a otras personas de los rayos del arco y chispas calientes con una cortina adecuada no-flamable como división.
6. Use careta protectora además de sus gafas de seguridad cuando esté removiendo escoria o puliendo. La escoria puede estar caliente y desprenderse con velocidad. Personas cercanas deberán usar gafas de seguridad y careta protectora.



#### FUEGO Y EXPLOSIONES

El calor de las flamas y el arco pueden ocasionar fuegos. Escoria caliente y las chispas pueden causar fuegos y explosiones.

Por lo tanto:

1. Remueva todo material combustible lejos del área de trabajo o cubra los materiales con una cobija a prueba de fuego. Materiales combustibles incluyen madera, ropa, líquidos y gases inflamables, solventes, pinturas, papel, etc.
2. Chispas y partículas de metal pueden introducirse en las grietas y agujeros de pisos y paredes causando fuegos escondidos en otros niveles o espacios. Asegúrese de que toda grieta y agujero esté cubierto para proteger lugares adyacentes contra fuegos.
3. No corte, suelde o haga cualquier otro trabajo relacionado hasta que la pieza de trabajo esté totalmente limpia y libre de sustancias que puedan producir gases inflamables o vapores tóxicos. No trabaje dentro o fuera de contenedores o tanques cerrados. Estos pueden explotar si contienen vapores inflamables.
4. Tenga siempre a la mano equipo extintor de fuego para uso instantáneo, como por ejemplo una manguera con agua, cubeta con agua, cubeta con arena, o extintor portátil. Asegúrese que usted esta entrenado para su uso.
5. No use el equipo fuera de su rango de operación. Por ejemplo, el calor causado por cable sobrecarga en los cables de soldar pueden ocasionar un fuego.
6. Después de terminar la operación del equipo, inspeccione el área de trabajo para cerciorarse de que las chispas o metal caliente ocasionen un fuego más tarde. Tenga personal asignado para vigilar si es necesario.
7. Para información adicional, haga referencia a la publicación NFPA Standard 51B, "Fire Prevention in Use of Cutting and Welding Processes", available from the National Fire Protection Association, Batterymarch Park, Quincy, MA 02269.



### CHOQUE ELECTRICO

**El contacto con las partes eléctricas energizadas y tierra puede causar daño severo o muerte. NO use soldadura de corriente alterna (AC) en áreas húmedas, de movimiento confinado en lugares estrechos o si hay posibilidad de caer al suelo.**

**Por lo tanto:**

1. Asegúrese de que el chasis de la fuente de poder esté conectado a tierra a través del sistema de electricidad primario.
2. Conecte la pieza de trabajo a un buen sistema de tierra física.
3. Conecte el cable de retorno a la pieza de trabajo. Cables y conductores expuestos o con malas conexiones pueden exponer al operador u otras personas a un choque eléctrico fatal.
4. Use el equipo solamente si está en buenas condiciones. Reemplace cables rotos, dañados o con conductores expuestos.
5. Mantenga todo seco, incluyendo su ropa, el área de trabajo, los cables, antorchas, pinza del electrodo, y la fuente de poder.
6. Asegúrese que todas las partes de su cuerpo están aisladas de ambos, la pieza de trabajo y tierra.
7. No se pare directamente sobre metal o tierra mientras trabaja en lugares estrechos o áreas húmedas; trabaje sobre un pedazo de madera seca o una plataforma aislada y use zapatos con suela de goma.
8. Use guantes secos y sin agujeros antes de energizar el equipo.
9. Apague el equipo antes de quitarse sus guantes.
10. Use como referencia la publicación ANSI/ASC Standard Z49.1 (listado en la próxima página) para recomendaciones específicas de como conectar el equipo a tierra. No confunda el cable de soldar a la pieza de trabajo con el cable a tierra.



### CAMPOS ELECTRICOS Y MAGNETICOS

**Son peligrosos. La corriente eléctrica fluye a través de cualquier conductor causando a nivel local Campos Eléctricos y Magnéticos (EMF). Las corrientes en el área de corte y soldadura, crean EMF alrededor de los cables de soldar y las maquinas.**

**Por lo tanto:**

1. Soldadores u Operadores que use marca-pasos para el corazón deberán consultar a su médico antes de soldar. El Campo Electromagnético (EMF) puede interferir con algunos marcapasos.
2. Exponerse a campos electromagnéticos (EMF) puede causar otros efectos de salud aún desconocidos.
3. Los soldadores deberán usar los siguientes procedimientos para minimizar exponerse al EMF:
  - a. Mantenga el electrodo y el cable a la pieza de trabajo juntos, hasta llegar a la pieza que usted quiere soldar. Asegúrelos uno junto al otro con cinta adhesiva cuando sea posible.
  - b. Nunca envuelva los cables de soldar alrededor de su cuerpo.
  - c. Nunca ubique su cuerpo entre la antorcha y el cable, a la pieza de trabajo. Mantenga los cables a un sólo lado de su cuerpo.
  - d. Conecte el cable de trabajo a la pieza de trabajo lo más cercano posible al área de la soldadura.
  - e. Mantenga la fuente de poder y los cables de soldar lo más lejos posible de su cuerpo.



### HUMO Y GASES

**El humo y los gases, pueden causar malestar o daño, particularmente en espacios sin ventilación. No inhale el humo o gases. El gas de protección puede causar falta de oxígeno.**

**Por lo tanto:**

1. Siempre provea ventilación adecuada en el área de trabajo por medio natural o mecánico. No solde, corte, o trabaje por medio natural o mecánico. No solde, corte, o ranure materiales con hierro galvanizado, acero inoxidable, cobre, zinc, plomo, berilio, o cadmio a menos que provea ventilación mecánica positiva. No respire los gases producidos por estos materiales.
2. No opere cerca de lugares donde se aplique sustancias químicas en aerosol. El calor de los rayos del arco pueden reaccionar con los vapores de hidrocarburo clorinado para formar un fosfógeno, o gas tóxico, y otros irritantes.
3. Si momentáneamente desarrolla irritación de ojos, nariz o garganta mientras está operando, es indicación de que la ventilación no es apropiada. Pare de trabajar y tome las medidas necesarias para mejorar la ventilación en el área de trabajo. No continúe operando si el malestar físico persiste.



- Haga referencia a la publicación ANSI/ASC Standard Z49.1 (Vea la lista a continuación) para recomendaciones específicas en la ventilación.
- ADVERTENCIA- Este producto cuando se utiliza para soldaduras o cortes, produce humos o gases, los cuales contienen químicos conocidos por el Estado de California de causar defectos en el nacimiento, o en algunos casos, Cáncer. (California Health & Safety Code §25249.5 et seq.)



### MANEJO DE CILINDROS

**Los cilindros, si no son manejados correctamente, pueden romperse y liberar violentamente gases. Rotura repentina del cilindro, válvula, o válvula de escape puede causar daño o muerte.**

**Por lo tanto:**

- Utilice el gas apropiado para el proceso y utilice un regulador diseñado para operar y reducir la presión del cilindro de gas. No utilice adaptadores. Mantenga las mangueras y las conexiones en buenas condiciones. Observe las instrucciones de operación del fabricante para montar el regulador en el cilindro de gas comprimido.
- Asegure siempre los cilindros en posición vertical y amárrelos con una correa o cadena adecuada para asegurar el cilindro al carro, transportes, tablleros, paredes, postes, o armazón. Nunca asegure los cilindros a la mesa de trabajo o las piezas que son parte del circuito de soldadura. Este puede ser parte del circuito eléctrico.
- Cuando el cilindro no está en uso, mantenga la válvula del cilindro cerrada. Ponga el capote de protección sobre la válvula si el regulador no está conectado. Asegure y mueva los cilindros utilizando un carro o transporte adecuado. Evite el manejo brusco de los
- Localice los cilindros lejos del calor, chispas, y flamas. Nunca establezca un arco en el cilindro.
- Para información adicional, haga referencia a la publicación CGA Standard P-1, "Precautions for Safe Handling of Compressed Gases in Cylinders", disponible a través del Compressed Gas Association, 1235 Jefferson Davis Highway, Arlington, VA 22202.



### MANTENIMIENTO DEL EQUIPO

**Equipo defectuoso o mal mantenimiento puede causar daño o muerte.**

**Por lo tanto:**

- Siempre tenga personal cualificado para efectuar la instalación, diagnóstico, y mantenimiento del equipo. No ejecute ningún trabajo eléctrico a menos que usted esté cualificado para hacer el trabajo.
- Antes de dar mantenimiento en el interior de la fuente de poder, desconecte la fuente de poder del suministro de electricidad primaria.
- Mantenga los cables, cable a tierra, conexiones, cable primario, y cualquier otra fuente de poder en buen estado operacional. No opere ningún equipo en malas condiciones.
- No abuse del equipo y sus accesorios. Mantenga el equipo lejos de cosas que generen calor como hornos, también lugares húmedos como charcos de agua, aceite o grasa, atmósferas corrosivas y las inclemencias del tiempo.
- Mantenga todos los artículos de seguridad y coberturas del equipo en su posición y en buenas condiciones.
- Use el equipo sólo para el propósito que fue diseñado. No modifique el equipo en ninguna manera.



### INFORMACION ADICIONAL DE SEGURIDAD

**Para más información sobre las prácticas de seguridad de los equipos de arco eléctrico para soldar y cortar, pregunte a su proveedor por una copia de "Precautions and Safe Practices for Arc Welding, Cutting and Gouging", Form 52-529.**

Las siguientes publicaciones, disponibles a través de la American Welding Society, 550 N.W. LeJeune Road, Miami, FL 33126, son recomendadas para usted:

- ANSI/ASC Z49.1 - "Safety in Welding and Cutting"
- AWS C5.1 - "Recommended Practices for Plasma Arc Welding"
- AWS C5.2 - "Recommended Practices for Plasma Arc Cutting"
- AWS C5.3 - "Recommended Practices for Air Carbon, Arc Gouging and Cutting"
- AWS C5.5 - "Recommended Practices for Gas Tungsten Arc Welding"
- AWS C5.6 - "Recommended Practices for Gas Metal Arc welding"
- AWS SP - "Safe practices" - Reprint, Welding Handbook
- ANSI/AWS F4.1 - "Recommended Safe Practices for Welding and Cutting of Containers That Have Held Hazardous Substances"



### SIGNIFICADO DE LOS SIMBOLOS

**Según usted avanza en la lectura de este folleto: Los Símbolos Significan ¡Atención! ¡Esté Alerta! Se trata de su seguridad.**



Significa riesgo inmediato que, de no ser evadido, puede resultar inmediatamente en serio daño personal o la muerte.



Significa el riesgo de un peligro potencial que puede resultar en serio daño personal o la muerte.



Significa el posible riesgo que puede resultar en menores daños a la persona.

## 3 MESURES DE SECURITE



**ATTENTION** : ces règles de sécurité ont pour objet d'assurer votre protection. Elles constituent une synthèse des mesures de sécurité contenues dans les ouvrages de référence repris au chapitre Informations complémentaires relatives à la Sécurité. Avant toute installation ou utilisation du matériel, veillez à lire et à respecter les règles de sécurité énoncées ci-dessous ainsi que dans les divers manuels, fiches de sécurité du matériel, étiquettes, etc. Le non-respect de ces précautions risque d'entraîner des blessures graves ou mortelles.



### PROTECTION INDIVIDUELLE ET DE L'ENTOURAGE

**Certains procédés de soudage, découpage et gougeage sont bruyants et requièrent le port de protections auditives. L'arc, tout comme le soleil, émet des ultraviolets (UV) et d'autres rayonnements susceptibles de provoquer des lésions oculaires et dermatologiques. Le métal chaud peut être à l'origine de brûlures. Une formation à l'utilisation correcte des procédés et équipements est essentielle pour prévenir les accidents. En conséquence :**

1. Porter impérativement des lunettes avec écrans latéraux dans les zones de travail, même lorsque le port du casque de soudage, de l'écran facial et des lunettes de protection est obligatoire
2. Tant pour exécuter les travaux que pour y assister, porter un écran facial muni de plaques protectrices et de verres filtrants appropriés pour protéger les yeux, le visage, le cou et les oreilles des étincelles et du rayonnement de l'arc. Avertir les personnes se trouvant à proximité qu'elles ne doivent pas regarder l'arc, ni s'exposer à son rayonnement ou à celui du métal incandescent.
3. Porter des gants ignifuges à crispins, une tunique épaisse à longues manches, des pantalons sans rebord, des chaussures à embout d'acier et un casque de soudage ou une casquette pour se protéger du rayonnement de l'arc, des étincelles et du métal incandescent. Le port d'un tablier ininflammable est également recommandé afin de se protéger des étincelles et du rayonnement thermique.
4. Les étincelles ou projections de métal en fusion risquent de se loger dans les manches retroussées, les bords relevés de pantalons ou dans les poches. Il convient donc de boutonner complètement les manches et le col, et de porter des vêtements sans poches à l'avant.
5. Protéger du rayonnement de l'arc et des étincelles les personnes se trouvant à proximité à l'aide d'un écran ou d'un rideau ininflammable approprié.
6. Porter des oculaires et des lunettes de protection pendant le meulage du laitier. Les particules meulées, souvent brûlantes, peuvent être projetées à des distances importantes, de sorte que les personnes se trouvant à proximité doivent également porter des lunettes de protection.



### INCENDIES ET EXPLOSIONS

**La chaleur dégagée par les flammes et les arcs peuvent être à l'origine d'incendies. Le laitier incandescent et les étincelles peuvent également provoquer incendies et explosions. En conséquence :**

1. Éloigner suffisamment tous les matériaux combustibles de la zone de travail ou les recouvrir complètement d'une bâche ignifuge. Ce type de matériaux comprend le bois, les vêtements, la sciure, les carburants sous forme liquide et gazeuse, les peintures, les enduits, le papier, etc.
2. Les étincelles ou projections de métal en fusion peuvent tomber dans les fissures du sol ou des murs et déclencher une combustion lente dans les planchers ou à l'étage inférieur. Veiller à protéger ces ouvertures pour que les étincelles et projections n'y pénètrent pas.
3. Ne pas procéder à des travaux de soudage, de découpage et autres travaux à chaud tant que la surface n'est pas complètement nettoyée et débarrassée des substances susceptibles de produire des vapeurs inflammables ou toxiques. Ne pas effectuer de travaux à chaud sur des conteneurs fermés pour éviter tout risque d'explosion.
4. Conserver à portée de main un équipement d'extinction – tuyau d'arrosage, seau d'eau ou de sable, extincteur portatif, etc. et s'assurer d'en connaître l'utilisation.
5. Ne pas utiliser l'équipement au-delà de ses spécifications. Par exemple, un câble de soudage surchargé est susceptible de surchauffer et d'être à l'origine d'un incendie.
6. Une fois le travail terminé, inspecter la zone de travail pour s'assurer qu'aucune étincelle ou projection de métal ne risque de déclencher un incendie. Le cas échéant, utiliser des systèmes de détection d'incendie.
7. Pour toute information supplémentaire, voir la norme NFPA 51B relative à la prévention des incendies lors de travaux de découpage et de soudage, disponible auprès de la National Fire Protection Association, Batterymarch Park, Quincy, MA 02269 – USA.



### CHOC ELECTRIQUE

**Tout contact avec des éléments sous tension et la masse peut provoquer des blessures graves ou mortelles. NE PAS utiliser de courant de soudage CA dans des zones humides, des lieux exigus ou lorsqu'il existe un risque de chute. En conséquence :**

1. Vérifier que le châssis du générateur est bien relié au dispositif de mise à la masse de l'alimentation.
2. Assurer une mise à la masse correcte de la pièce à souder.
3. Connecter le câble de soudage à la pièce à souder. Un raccordement médiocre ou inexistant constitue un risque mortel pour l'utilisateur et son entourage.
4. Utiliser du matériel correctement entretenu. Remplacer les câbles usés ou endommagés.
5. Empêcher l'apparition de toute humidité, notamment sur les vêtements, dans la zone de travail, sur les câbles, la torche de soudage, le porte-électrode et le générateur.
6. S'assurer que le corps est totalement isolé de la pièce à souder et de la masse.
7. Éviter tout contact direct avec du métal ou la masse lors de travaux dans des endroits exigus et en zone humide ; se tenir sur des panneaux ou sur une plate-forme isolante et porter des chaussures à semelles en caoutchouc.
8. Enfiler des gants secs et sans trous avant de mettre l'équipement sous tension.
9. Mettre l'équipement hors tension avant de retirer les gants.
10. Voir la norme ANSI/ASC Z49.1 (voir page suivante) pour les recommandations de mise à la masse. Ne pas confondre le câble de soudage et le câble de masse.



### CHAMPS ELECTRIQUES ET MAGNETIQUES

**Danger. Le courant électrique parcourant les conducteurs génère localement des champs électriques et magnétiques (EMF). Le courant de soudage et de découpe crée des EMF autour des câbles de soudage et des postes à souder. En conséquence :**

1. Les porteurs de stimulateurs cardiaques consulteront leur médecin avant d'effectuer des travaux de soudage. Les EMF peuvent en effet provoquer des interférences.
2. L'exposition aux EMF peut également avoir des effets méconnus sur la santé.
3. Les soudeurs respecteront les procédures suivantes pour réduire l'exposition aux EMF :
  - a. Rassembler en faisceau les câbles de soudage et d'électrode. Si possible, les attacher avec du ruban adhésif.
  - b. Ne jamais enrouler le câble de la torche ou le câble de soudage autour du corps.
  - c. L'utilisateur ne doit jamais se trouver entre le câble de la torche et le câble de soudage. Faire passer tous les câbles du même côté du corps.
  - d. Connecter le câble de soudage à la pièce à souder, au plus près de l'endroit du soudage.
  - e. S'éloigner au maximum du générateur et des câbles.



### FUMÉES ET GAZ

**L'inhalation des fumées et gaz peut provoquer des malaises et des dommages corporels, surtout lors de travaux dans les espaces confinés. Ne pas les respirer. Les gaz inertes peuvent causer l'asphyxie. En conséquence :**

1. Assurer une aération adéquate de la zone de travail par une ventilation naturelle ou mécanique. Ne pas effectuer de travaux de soudage, découpage ou gougeage sur des matériaux tels que l'acier galvanisé, le cuivre, le zinc, le plomb, le béryllium et le cadmium en l'absence d'une ventilation mécanique adéquate. Ne pas inhaler les fumées dégagées par ces matériaux.
2. Ne pas travailler à proximité d'opérations de dégraissage et de pulvérisation étant donné que la chaleur dégagée et l'arc peut réagir avec les hydrocarbures chlorés pour former du phosgène – un gaz particulièrement toxique – et d'autres gaz irritants.
3. Une irritation momentanée des yeux, du nez ou de la gorge provoquée par les travaux est le signe d'une ventilation inappropriée. Dans ce cas, il convient d'arrêter le travail et de prendre les mesures nécessaires pour améliorer l'aération. Ne pas poursuivre le travail si le malaise persiste.
4. Voir la norme ANSI/ASC Z49.1 (voir ci-dessous) pour les recommandations de ventilation.
5. ATTENTION : utilisé dans des opérations de soudage et de découpage, ce produit dégage des fumées et gaz qui contiennent des substances chimiques reconnues par l'État de Californie comme pouvant être à l'origine de malformations congénitales et de cancers (California Health & Safety Code §25249.5 et seq.).



**MANIPULATION DES BOUTEILLES DE GAZ**

**Une erreur de manutention des bouteilles de gaz peut les endommager et entraîner une libération violente du gaz. La rupture soudaine de la soupape ou du détendeur peut provoquer des blessures graves ou mortelles.**

**En conséquence :**

1. Utiliser le gaz approprié à la pression adéquate, celle-ci étant réglée par un détendeur adapté au type de bouteille utilisée. Ne pas utiliser d'adaptateurs. Garder les tuyaux et accessoires en bon état. Pour le montage du détendeur sur une bouteille de gaz comprimé, suivre les instructions du fabricant.
2. Fixer les bouteilles verticalement – au moyen d'une chaîne ou d'une sangle – à un chariot à bras, un châssis de roulement, un banc, un mur, un piquet ou un rack. Ne jamais attacher les bouteilles aux établis et éléments susceptibles de les intégrer à un circuit électrique.
3. Conserver les bouteilles fermées lorsqu'elles ne sont pas utilisées. Les fermer par un bouchon lorsqu'elles ne sont pas raccordées. Attacher et déplacer les bouteilles à l'aide de chariots adéquats.
4. Éloigner les bouteilles des sources de chaleur, d'étincelles et de flammes nues. Ne jamais déclencher d'arc sur une bouteille de gaz.
5. Pour plus d'informations sur les précautions d'utilisation des bouteilles de gaz comprimé, voir la norme CGA P-1, disponible auprès de la Compressed Gas Association, 1235 Jefferson Davis Highway, Arlington, VA 22202 – USA.



**ENTRETIEN DE L'EQUIPEMENT**

**Un équipement mal entretenu peut provoquer des blessures graves ou mortelles. En conséquence :**

1. Confier l'installation, les dépannages et l'entretien à du personnel qualifié. Ne pas effectuer de travaux électriques si vous ne possédez pas les compétences requises.
2. Mettre l'équipement hors tension avant toute intervention d'entretien sur le générateur.
3. Maintenir en bon état de fonctionnement les câbles, câbles de masse, connexions, cordons d'alimentation et générateurs. Ne jamais utiliser d'équipements défectueux.
4. Ne jamais surcharger les équipements et accessoires. Conserver les équipements à l'écart des sources de chaleur – notamment des fours –, des flaques d'eau, des traces d'huile ou de graisse, des atmosphères corrosives et des intempéries.
5. Laisser en place tous les dispositifs de sécurité et tous les panneaux du tableau de commande en veillant à les garder en bon état.
6. Utiliser l'équipement conformément à l'usage prévu ; n'y apporter aucune modification quelconque.



**INFORMATIONS COMPLEMENTAIRES RELATIVES A LA SECURITE** Pour plus d'informations relatives aux règles de sécurité pour les travaux de gougeage, de découpage et de soudage à l'arc électrique, demander au fournisseur une copie du formulaire 52/529.

L'American Welding Society, 550 N.W. LeJuene Road, Miami, FL 33126 – USA, publie les documents suivants dont la lecture est également recommandée :

1. ANSI/ASC Z49.1 - "Safety in Welding and Cutting"
2. AWS C5.1 - "Recommended Practices for Plasma Arc Welding"
3. AWS C5.2 - "Recommended Practices for Plasma Arc Cutting"
4. AWS C5.3 - "Recommended Practices for Air Carbon, Arc Gouging and Cutting"
5. AWS C5.5 - "Recommended Practices for Gas Tungsten Arc Welding"
6. AWS C5.6 - "Recommended Practices for Gas Metal Arc welding"
7. AWS SP - "Safe practices" - Réédition, Manuel de soudage
8. ANSI/AWS F4.1 - "Recommended Safe Practices for Welding and Cutting of Containers That Have Held Hazardous Substances"



**SYMBLES**

**Signification des symboles utilisés dans ce manuel : = Attention ! Rester prudent !**



= danger immédiat ; risque de blessures graves ou mortelles.



= danger potentiel ; risque de blessures graves ou mortelles.



= danger ; risque de blessures légères.



---

## 4 USER RESPONSIBILITY

---

This equipment will perform in conformity with the description thereof contained in this manual and accompanying labels and/or insert when installed, operated, maintained and repaired in accordance with the instruction provided. This equipment must be checked periodically. Defective equipment should not be used. Parts that are broken, missing, worn, distorted or contaminated should be replaced immediately. Should such repair or replacement become necessary, the manufacturer recommends that a telephone or written request for service advice be made to the Authorized Distributor from whom it was purchased.

This equipment or any of its parts should not be altered without the prior written approval of the manufacturer. The user of this equipment shall have the sole responsibility for any malfunction which results from improper use, faulty maintenance, damage improper repair or alteration by anyone other than the manufacturer or a service facility designated by the manufacturer.

---

## 5 SAFETY

---

Before the Mig 5000i power source is put into operation, the safety precautions on page 3 and safety on page 11 should be read completely. This will help avoid possible injury due to misuse or improper installation.

Users of ESAB welding equipment have the ultimate responsibility for ensuring that anyone who works on or near the equipment observes all the relevant safety precautions. Safety precautions must meet the requirements that apply to this type of welding equipment. The following recommendations should be observed in addition to the standard regulations that apply to the workplace.

All work must be carried out by trained personnel well-acquainted with the operation of the welding equipment. Incorrect operation of the equipment may lead to hazardous situations which can result in injury to the operator and damage to the equipment.

1. Anyone who uses the welding equipment must be familiar with:
  - its operation
  - location of emergency stops
  - its function
  - relevant safety precautions
  - welding
2. The operator must ensure that:
  - no unauthorized person is stationed within the working area of the equipment when it is started up.
  - no-one is unprotected when the arc is struck
3. The workplace must:
  - be suitable for the purpose
  - be free from drafts
4. Personal safety equipment
  - Always wear recommended personal safety equipment, such as safety glasses, flame-proof clothing, safety gloves.
  - Do not wear loose-fitting items, such as scarves, bracelets, rings, etc., which could become trapped or cause burns.
5. General precautions
  - Make sure the ground cable is connected securely.
  - Work on high voltage equipment **may only be carried out by a qualified electrician.**
  - Appropriate fire extinguishing equipment must be clearly marked and close at hand.
  - Lubrication and maintenance must **not** be carried out on the equipment during operation.

**ESAB can provide you with all necessary welding protection and accessories.**

 **WARNING!**  
Read and understand the instruction manual before installing or operating.

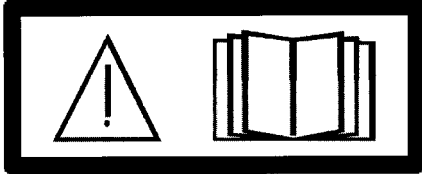

 **WARNING!**  
Do not use the power source for thawing frozen pipes.

 **This product is solely intended for arc welding.**

## 6 INTRODUCTION

The **Mig 5000i** is a GMA welding power source, which can also be used for SMAW (Shielded Metal Arc Welding ).

The power source is intended for use with the Feed 3004 or Feed 4804 wire feed units.

All settings are made from the wire feed unit or control box U8.

**ESAB's accessories for the product can be found on page 25.**

### 6.1 Equipment

The power source is supplied complete with terminating resistor and instruction manual.

## 7 TECHNICAL DATA

	Mig 5000i
<b>Mains voltage</b>	460V, ± 10%, 3~ 60 Hz
<b>Primary current</b>	
$I_{max}$ GMAW	35 A
$I_{max}$ SMAW	36 A
<b>No-load power</b> demand when in the energy-saving mode, 6.5 min. after welding	70 W
<b>Voltage/current range</b>	
GMAW	8-60 V / 16-500 A
GMAW, control panel M2	8 - 42 V
SMAW	4 - 500 A
<b>Permissible load at GMAW</b>	
60 % duty cycle	500 A / 39 V
100% duty cycle	400 A / 34 V
<b>Permissible load at SMAW</b>	
60 % duty cycle	500 A / 40 V
100% duty cycle	400 A / 36 V
<b>Power factor</b> at maximum current	0.83

	Mig 5000i
<b>Efficiency</b> at maximum current	87 %
<b>Open-circuit voltage</b> GMAW SMAW	72 - 88 V 68 - 80 V
<b>Operating temperature</b>	-10 to +40 °C
<b>Dimensions, l x w x h</b>	24.6" x 15.5" x 19.5"
<b>Continual A-weighted sound pressure</b>	<70 db
<b>Weight</b>	150 lbs
<b>Insulation class</b> transformer	H
<b>Enclosure class</b>	IP 23
<b>Application class</b>	<b>S</b>

**Duty cycle**

The duty cycle refers to the time as a percentage of a ten-minute period that you can weld at a certain load without overloading.

**Enclosure class**

The IP code indicates the enclosure class, i. e. the degree of protection against penetration by solid objects or water. Equipment marked **IP 23** is designed for indoor and outdoor use.

**Application class**

The symbol **S** indicates that the power source is designed for use in areas with increased electrical hazard.

## 8 INSTALLATION

*The installation must be done by a professional.*



**WARNING!**

This product is intended for industrial use. In a domestic environment this product may cause radio interference. It is the user's responsibility to take adequate precautions.

### 8.1 Lifting instructions



### 8.2 Placing

Position the welding power source such that its cooling air inlets and outlets are not obstructed.

### 8.3 Primary input





**WARNING**

**ELECTRIC SHOCK CAN KILL!** Precautionary measures should be taken to provide maximum protection against electrical shock.

Be sure that all power is OFF by opening the line (wall) disconnect switch when primary electrical connections are made to the power source.

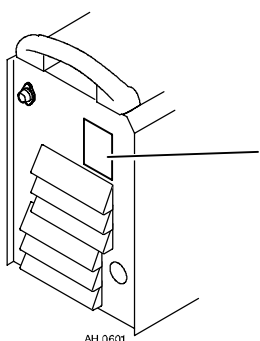
Be sure to check your input leads with a voltmeter to make sure all power is OFF.



Check that the unit is connected to the correct mains power supply voltage, and that it is protected by the correct fuse sizes. A protective earth connection must be made, in accordance with regulations.

*Rating plate with supply connection data*

#### Recommended fuse sizes and minimum cable areas

Mig 5000i	460 V 3~ 60 Hz
<b>Mains voltage</b>	460 V
<b>Mains cable area, CU/AWG (mm<sup>2</sup>)</b>	4G6
<b>Phase current, I RMS</b>	28 A
<b>Fuse Time Delay</b>	50 A

**NB!** Sizes per National Electric Code for 90°C rated cooper conductors @30°C ambient. Not more than three conductors in raceway or cable. Local codes should be followed if they specify larger sizes other than those listed above.

### 8.4 Terminating resistor

In order to avoid communication interference, the ends of the CAN bus must be fitted with terminating resistors.

One end of the CAN bus is at the control panel, which has an integral terminating resistor. The other end at the power source must be fitted with the terminating resistor, as shown on the right.

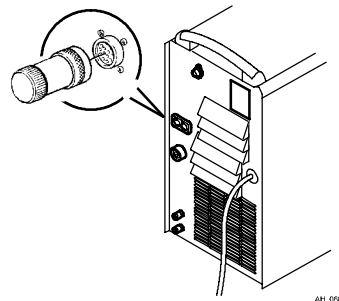

## 9 OPERATION

**General safety regulations for the handling of the equipment can be found on page 11. Read through before you start using the equipment!**

### 9.1 Connections and control devices

- |   |  |   |   |
|---|--|---|---|
| 1 | Connection for welding current cable (+)<br>(SMAW welding) | 5 | White indicating lamp - Power supply ON |
| 2 | Connection for remote control                              | 6 | Orange indicating lamp - Overheating    |
| 3 | Connection for return cable (-)                            | 7 | Fuse                                    |
| 4 | Main power supply switch, 0 / 1 / START                    |   |   |

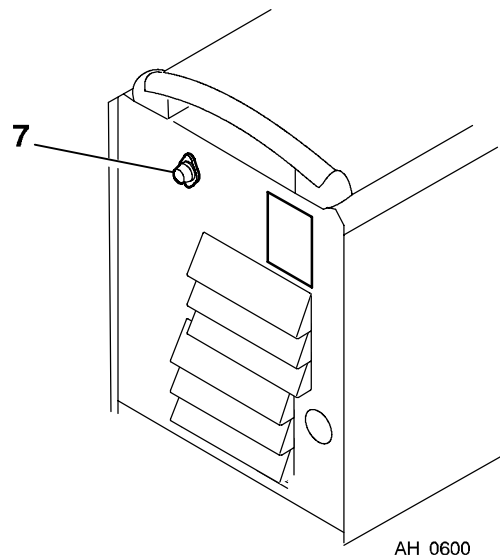
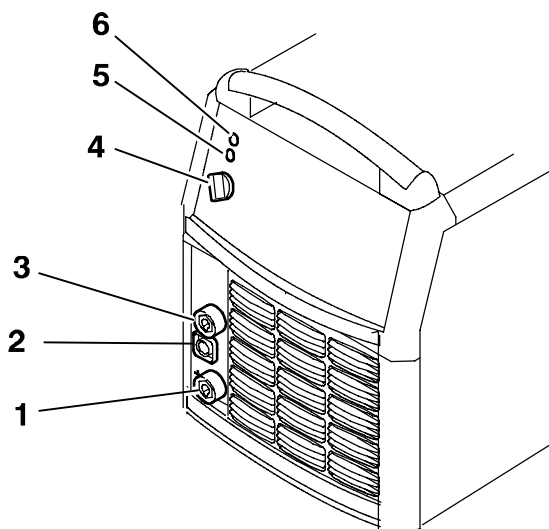

### 9.2 Turning on the power source

Turn on the mains power by turning switch (7) to the "START" position. Release the switch, and it will return to the "1" position.

If the mains power supply should be interrupted while welding is in progress, and then be restored, the power source will remain de-energised until the switch is again turned manually to the "START" position.

Turn the unit off by turning the switch to the "0" position.

In the event of a loss of supply power or of turning the power source off in the normal manner, welding data will be stored so that it is available next time the unit is started.



### 9.3 Fan control

The power source fans continue to run for 6.5 minutes after welding has stopped, and the unit switches to energy-saving mode. They start again when welding restarts.

The fans run at reduced speed for welding currents up to 180 A, and at full speed for higher currents.

### 9.4 Overheating protection

The power source has three thermal overload trips which operate if the internal temperature becomes too high, interrupting the welding current and lighting the orange indicating lamp on the front of the unit. They reset automatically when the temperature has fallen.

### 9.5 Remote control unit

The program version in U8 should be 1.20 or higher. Machines with integral control panels should have program version 1.21 or higher, in order for the remote control to function correctly.

When the remote control unit is connected, the power source and wire feed unit are in remote control mode; the buttons and knobs are blocked. The functions can only be adjusted via the remote unit.

If the remote control unit is not to be used, the remote control unit must be disconnected from the power source / wire feed unit, as otherwise it will remain in remote control mode.

For more information about the operation of the remote control unit, see the operating instructions for the control panel.

---

## 10 MAINTENANCE

---



*Regular maintenance is important for safe, reliable operation.*

*Maintenance must be done by a professional.*

*Only those persons who have appropriate electrical knowledge (authorized personnel) may remove the safety plates.*

**Note!**

*Supplier warranty is void if customer attempts any work on product during the warranty period.*

## 10.1 Cleaning the air filter

- Release the cover plate with the dust filter (1).
- Swing out the cover plate (2).
- Remove the dust filter (3).
- Blow it clean with compressed air at reduced pressure.
- Replace the filter with the finer mesh on the side against the cover plate (2).
- Replace the cover plate with the filter.

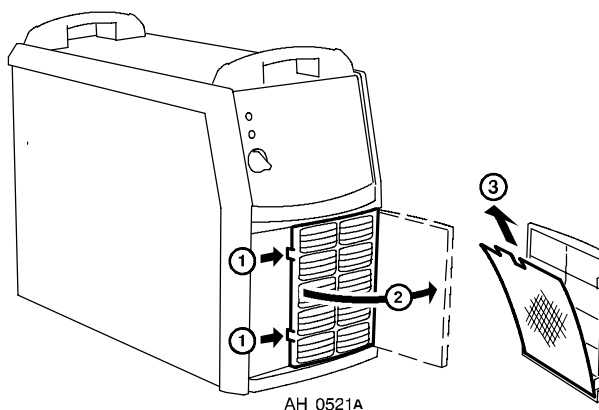

## 11 TROUBLESHOOTING

*Try these recommended checks and inspections before sending for an authorized service technician.*



Type of fault	Action
No arc.	<ul style="list-style-type: none"> <li>• Check that the mains power supply switch is turned on.</li> <li>• Check that the welding current supply and return cables are correctly connected.</li> <li>• Check that the correct current value is set.</li> <li>• Check the fuse.</li> </ul>
Welding current is interrupted during welding	<ul style="list-style-type: none"> <li>• Check whether the thermal overload trips have operated (indicated by the orange lamp on the front panel).</li> <li>• Check the main power supply fuses.</li> </ul>
The thermal overload trips operate frequently.	<ul style="list-style-type: none"> <li>• Check to see whether the air filters are clogged.</li> <li>• Make sure that you are not exceeding the rated data for the power source (i.e. that the unit is not being overloaded).</li> </ul>
Poor welding performance.	<ul style="list-style-type: none"> <li>• Check that the welding current supply and return cables are correctly connected.</li> <li>• Check that the correct current value is set.</li> <li>• Check that the correct wire is being used.</li> <li>• Check the main power supply fuses.</li> </ul>

## 12 REPLACEMENT AND REPAIR PARTS

*Repair and electrical work should be performed by an authorized ESAB service personnel. Use only ESAB original replacement and wear parts.*

When ordering replacement parts, order by part number and part name, as illustrated on the figure. Always provide the series or serial number on the unit on which the parts will be used. The serial number is stamped on the rating plate.



## 12.1 Ordering

To assure proper operation, it is recommended that only genuine ESAB parts and products be used with this equipment.

Replacement parts may be ordered from your ESAB distributor or from:

**ESAB Welding & Cuttin Products**  
**Attn: Customer Service Dept.**  
**P.O. Box 100545, 411 S. Ebenezer Road**  
**Florence, SC 29501-0545**

To order parts by phone, contact ESAB at 1-843-664-5540. Orders may also be faxed to 1-800-634-7548. Be sure to indicate any special shipping instructions when ordering replacement parts.

Refer to the Communication Guide located on the last page of this manual for a list of customer service phone numbers.



# Schematic diagram

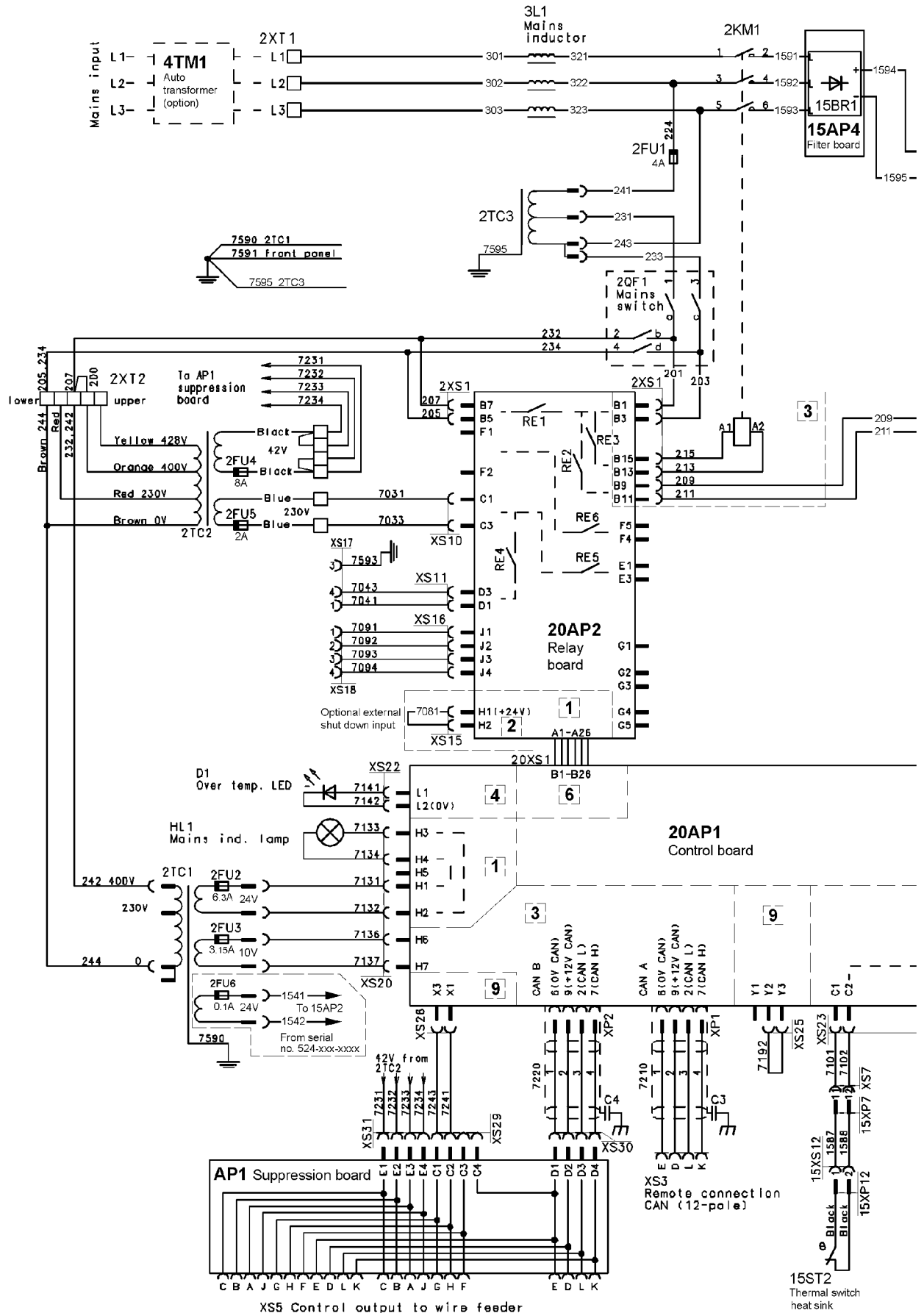

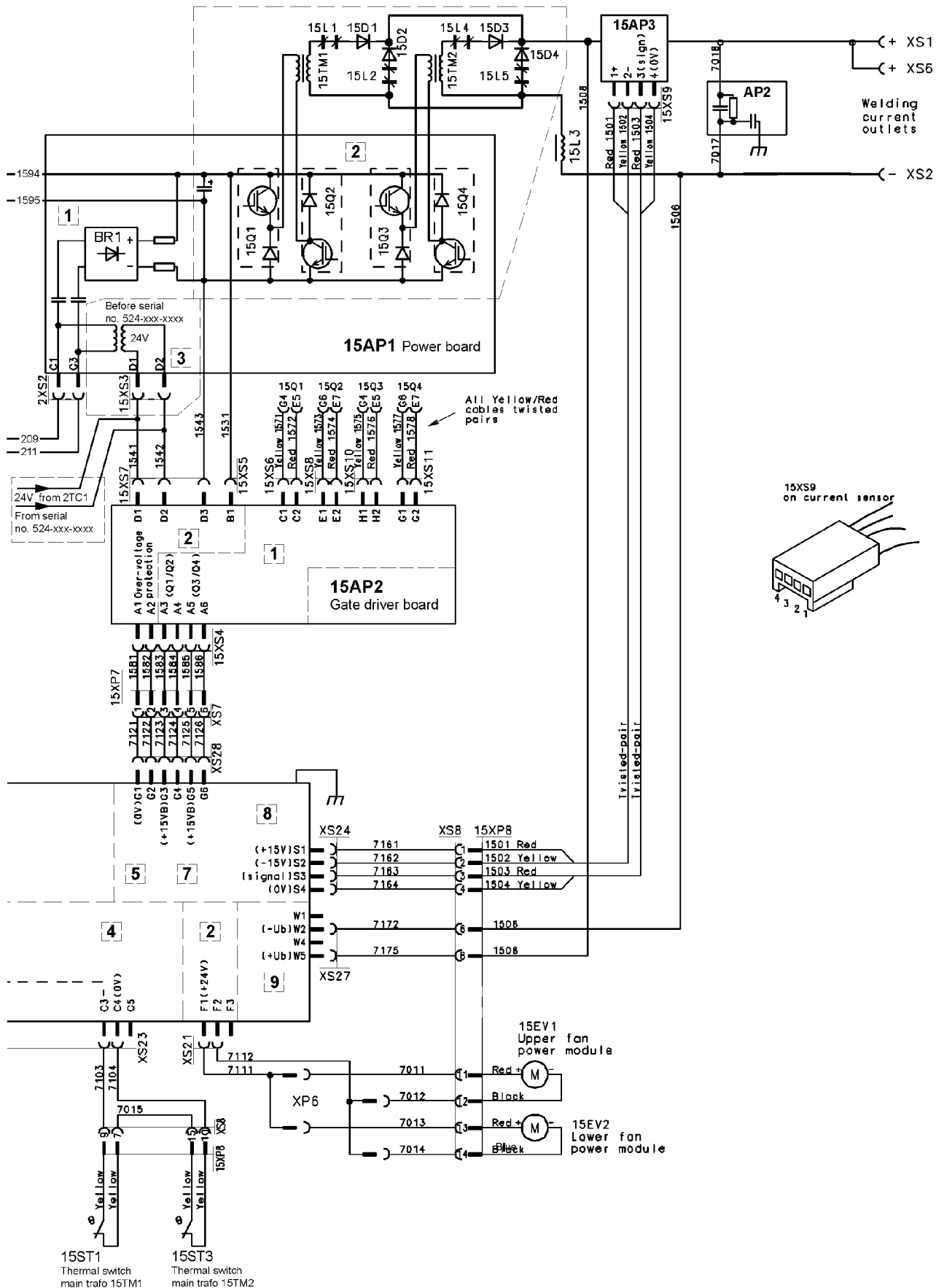



## Mig 5000i

### Ordering number

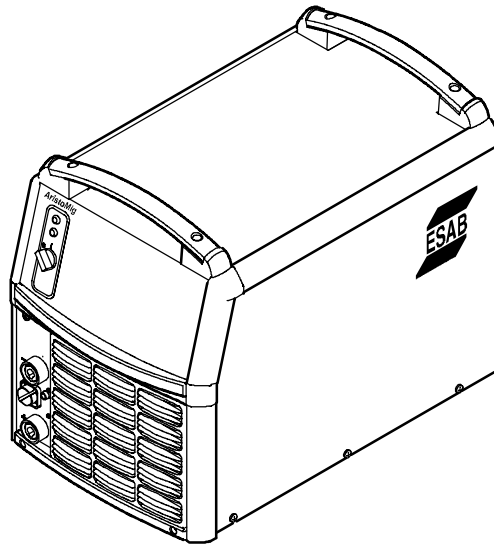

Ordering no.	Denomination	Type	Notes
0459 230 884	Welding power source	Mig 5000i	
0459 293 990	Spare part list	Mig 5000i	

The spare parts list is available on the Internet at [www.esab.com](http://www.esab.com)  
Under "Products" and "Welding & cutting equipment", you will find a link to the page where you can both search for and download instruction manuals and spare parts lists.

# Mig 5000i

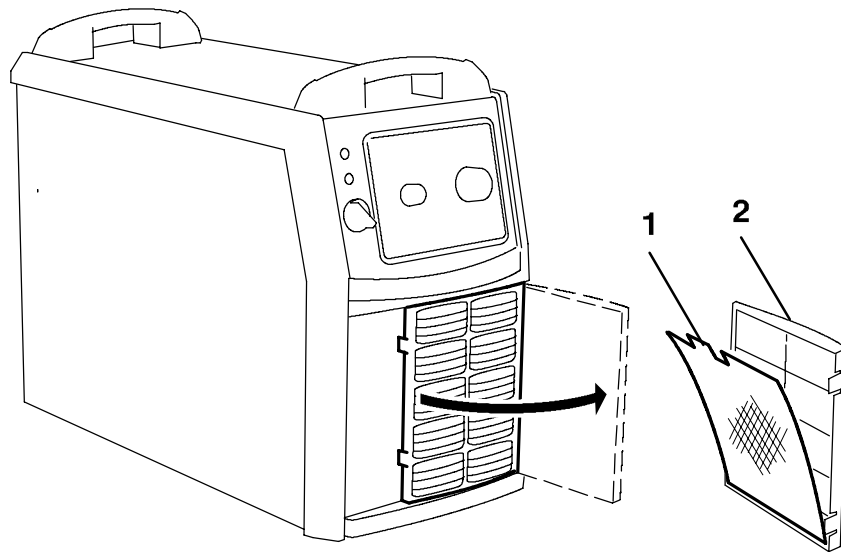

## Replacement parts

Item	Ordering no.	Denomination
1	0458 398 001	Filter
2	0458 383 001	Front grill





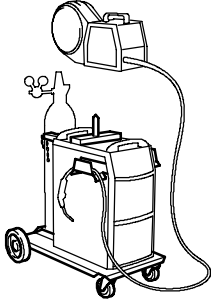
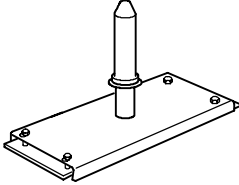
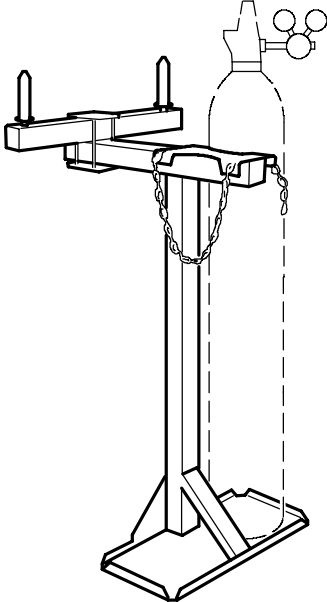
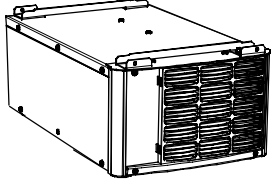

# Mig 5000i

## Accessories

	<p><b>Cart</b> ..... 0458 530 880</p>
	<p><b>Guide pin</b> ..... 0458 731 880</p>
	<p><b>Feeder stand</b> ..... 0458 522 880</p>
	<p><b>Autotransformer TUA2</b> ..... 0459 145 880</p>
	<p><b>Remote control adapter RA12</b> 12 pole ..... 0459 491 910 For analogue remote controls to CAN based equipment.</p>

**Mig 5000i**

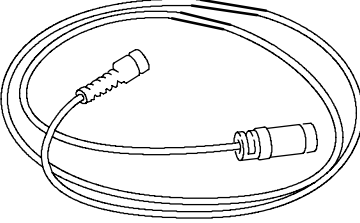
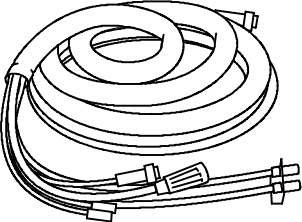
	<p><b>Remote control unit MTA1 CAN</b> ..... 0459 491 880</p> <p>GMAW: wire feed speed and voltage          SMAW: current and arc force          GTAW: current, pulse and background current</p>
	<p><b>Remote control unit M1 10Prog CAN</b> ..... 0459 491 882</p> <p>Choice of on of 10 programs          GMAW: voltage deviation          GTAW and SMAW: current deviation</p>
	<p><b>Remote control unit AT1 CAN</b> ..... 0459 491 883</p> <p>SMAW and GTAW: current</p>
	<p><b>Remote control unit AT1 CF CAN</b> ..... 0459 491 884</p> <p>SMAW and GTAW:          rough and fine setting of current.</p>
	<p><b>Remote control cable 12 pole - 4 pole</b></p> <p>16.4 ft ..... 0459 554 880          32.9 ft ..... 0459 554 881          49.4 ft ..... 0459 554 882          82.2 ft ..... 0459 554 883          0.8 ft ..... 0459 554 884</p>
	<p><b>Connection set</b></p> <p>5.6 ft ..... 0456 528 880          16.4 ft ..... 0456 528 890          32.9 ft ..... 0456 528 881          49.4 ft ..... 0456 528 882          82.0 ft ..... 0456 528 883          115 ft ..... 0456 528 884</p>

**Mig 5000i**

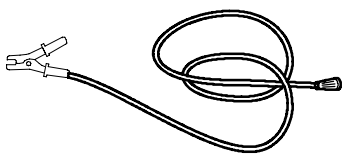
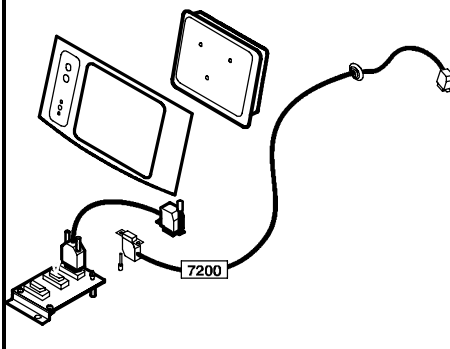
	<p><b>Return cable</b> 16.4 ft 2/0 AWG ..... 0700 006 895</p>
	<p><b>MMC kit for power source Mig</b> ..... 0459 579 880</p>

**ESAB Welding & Cutting Products, Florence, SC Welding Equipment  
COMMUNICATION GUIDE - CUSTOMER SERVICES**

- A CUSTOMER SERVICE QUESTIONS:  
**Telephone: (800) 362-7080 / Fax: (800) 634-7548** **Hours: 8.00 AM to 7:00 PM EST**  
Order Entry    Product Availability    Pricing    Order Information    Returns
- B ENGINEERING SERVICE:  
**Telephone: (834) 664-4416 / Fax: (800) 446-5693** **Hours: 7.30 AM to 5:00 PM EST**  
Warranty Returns    Authorized Repair Stations    Welding Equipment Troubleshooting
- C TECHNICAL SERVICE:  
**Telephone: (800) ESAB-123 / Fax: (843) 664-4452** **Hours: 8.00 AM to 5:00 PM EST**  
Part Numbers    Technical Applications    Specifications    Equipment Recommendations
- D LITERATURE REQUESTS:  
**Telephone: (843) 664-5562 / Fax: (843) 664-5548** **Hours: 7.30 AM to 4:00 PM EST**
- E WELDING EQUIPMENT REPAIRS:  
**Telephone: (843) 664-4487 / Fax: (843) 664-5557** **Hours: 7.30 AM to 3:30 PM EST**  
Repair Estimates    Repair Status
- F WELDING EQUIPMENT TRAINING:  
**Telephone: (843) 664-4428 / Fax: (843) 679-5864** **Hours: 7.30 AM to 4:00 PM EST**  
Training School Information and Registrations
- G WELDING PROCESS ASSISTANCE:  
**Telephone: (800) ESAB-123** **Hours: 7.30 AM to 4:00 PM EST**
- H TECHNICAL ASST. CONSUMABLES:  
**Telephone: (800) 933-7070** **Hours: 7.30 AM to 5:00 PM EST**

**IF YOU DO NOT KNOW WHOM TO CALL**

Telephone: (800) ESAB-123  
Fax: (843) 664-4452  
Hours: 7:30 AM to 5:00 PM EST

or

visit us on the web at <http://www.esabna.com>

The ESAB web site offers:  
Comprehensive Product Information  
Material Safety Data Sheets  
Warranty Registration  
Instruction Literature Download Library  
Distributor Locator  
Global Company Information  
Press Releases  
Customer Feedback & Support



**ESAB Welding & Cutting Products**  
PO BOX 100545, Florence SC 29501-0545